



***AUTOMATIC DUST COLLECTION
FOR SMALL SHOPS***

INSTRUCTIONS

***GG500B MOTOR CONTACTOR
WITH THERMAL PROTECTION***

115VAC COIL

Thank you for choosing our Automatic Dust Collection System.

We at Grngate have developed what we hope will be a valuable addition to your shop. Numerous articles have been written about the health risks associated with sawdust. Our goal is to provide you, the woodworker, with both a cleaner and safer shop. Making the entire dust collection operation totally automatic and synchronized with the actual machine operation allows the user to maximize his/her enjoyment of their shop time.

Our staff includes professional design engineers and manufacturing personnel who are also dedicated woodworking enthusiasts. We have tried to address many of the issues with both installation and operation we have encountered over many years of experience. We wish you many years of chip making enjoyment!

Chuck & Petr

MODEL GG500B THREE POLE MOTOR CONTACTOR

The Three Pole Motor Contactor accessory extends the dust collector motor rating up to 5HP and supports 1, 2 or 3 phase motors. A thermal motor protection module is part of the contactor providing sensing of faults such as jam/stall, underload and phase unbalance.



WHAT'S IN THE BOX

The Motor Contactor accessory contains:

- 1- MOTOR CONTACTOR
- 1- SHUNT (JUMPER)
- 1- INSTRUCTION MANUAL

The Contactor has a pre-wired power cable for connection to the System Controller.

What's not in the box is the AC wiring required to connect the Motor Contactor to the AC power and dust collector. Since each installation will be unique with various power plug choices, types of wire and wiring length, we feel strongly it is safer for the user to work with a licensed electrician to determine what the installation requires.

INSTALLATION

OK, it's time to add the Contactor to your system.

MOUNTING

The unit has a three foot power cable that will be connected to the System Controller. Mount the Contactor close enough to the System Controller to allow for this connection.

There are several mounting holes on the flanges of the unit. Two are on the upper and lower flanges. You can drill out the holes to a larger size if you need to accommodate a larger screw diameter.

Try to mount the unit such that at least one screw will be into a stud. If you must mount it onto drywall, use some sort of toggle bolt, plastic wall anchor or other drywall attachment means. Most hardware centers will have various product offerings.

WIRING

SYSTEM CONTROLLER VOLTAGE SELECTION

Whatever power you will be using for your dust collector, the System Controller ***MUST*** be connected to 115 VAC, ***not*** 220 VAC. Although the System Controller is capable of being powered with either 115 VAC or 230 VAC, ***you must select 115 VAC.***

WARNING: Powering the System Controller from 220 VAC will permanently damage the Motor Contactor.

We suggest you select this voltage option right now so it won't be forgotten later.

The System Controller has a voltage selection switch inside.

The top cover is removed by removing the six screws around the perimeter. The cover can now be removed. CAUTION- there is a cable connecting electronic assemblies in the top and bottom halves of the case. Please don't put undue strain on this cable.

Use a small flat blade screwdriver and slide the switch actuator so the 115V voltage shows on the switch.



**FAILURE TO SELECT THE CORRECT
VOLTAGE RANGE WILL RESULT IN
PERMANENT DAMAGE TO THE
CONTACTOR**

MOTOR CONTACTOR-TO-CONTROLLER WIRING

The Motor Contactor has a three foot pre-wired cable. The free end of this cable is already prepared for connection to the System Controller. Insert the cable through the right hand cable gland on the System Controller. If the cable won't slide through, try opening up the clamp on the gland by turning it counter clockwise. It may be somewhat hard the turn and will have a clicking sound as it turns.

Pull the cable through so that there is sufficient length to be able to insert the wire ends into the terminal block.

Now insert the wire ends into the terminal block labeled LOAD with the wire color matching the label on the board. If the wire doesn't insert, make sure the terminal block opening is fully open.

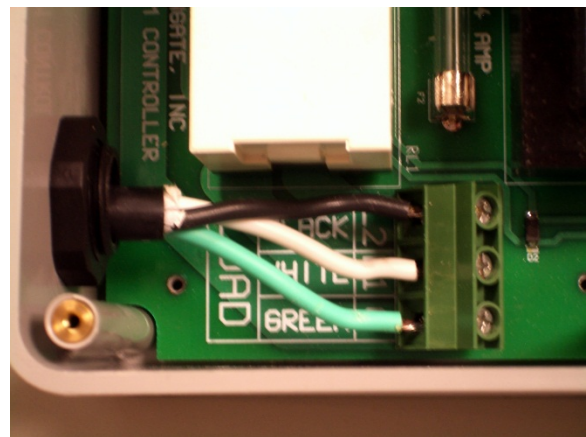

Turn the screw on the top of the terminal block counter-clockwise to open up the connection recess. After the wire end is fully inserted into the block there should be no exposed bare wire. Hold the wire firm and turn the screw clockwise until it is snug. Give it just a little more without over tightening to ensure a good contact

After all three wires are securely tightened, allow a little slack in the cable and twist the gland nut clockwise until it firmly grips the cable.

Any excess cable between the boxes can be bundled up and fastened with a tie wrap or tape.

SYSTEM CONTROLLER AC WIRING

As part of the installation of the System Controller, the instruction manual for the Starter System covered the wiring of this component. However, rather than wiring the System Controller to your dust collector, it will be wired to the Motor Contactor.

You purchased the Motor Contactor because you have a larger dust collector motor that requires the Contactor's higher current capability. Your collector motor may be either single or three phase. The contactor has three poles (contacts) that allow for either type.

You will use two poles for a single phase motor and all three poles for a three phase motor.

The size and type of collector motor will determine the required size of the wiring. There are too many variables for us to list specific wire sizes and circuit breaker recommendations.

CONSULT THE SERVICES OF A LICENSED ELECTRICIAN AND FOLLOW ALL LOCAL BUILDING CODE REQUIREMENTS.

MOTOR CONTACTOR-TO-COLLECTOR SINGLE PHASE AC WIRING

The top cover of the Motor Contactor is removed by removing the four screws around the top perimeter.

Depending on your installation, you may be using power plugs and sockets, direct wiring into junction boxes or a combination of both.

The wires in three conductor cable for a single phase motor are usually white, black with the safety wire being either green or bare. The fourth wire in four conductor cable for three phase motors is usually red.

SINGLE PHASE WIRING- MOTOR CONTACTOR TO COLLECTOR MOTOR

Remove (strip) the insulation back about 1/2 inch from all the wire ends.

Insert the prepared cable through the right hand cable gland. Pull the cable through so that there is sufficient length to be able to attach to the terminals of the Contactor. The wires will be connected to the terminals on the Contactor terminals labeled T1 and T3.

Leave the green (or bare) safety wire free for now.

Sufficiently unscrew the terminal screws on the contactor to allow the stripped wire ends to be slipped under the square washers. Now tighten the screws snugly. The wire ends should have little or no exposed bare wire. But make sure there is no insulation under the clamping washers. Tighten the screws just a little more without over tightening to ensure a good contact. If you are using stranded wire and did not tin the wire ends, make sure that there are no strands of exposed wire. If there are, remove the wire, re-twist the bare wire end and re-attach and tighten.

After all the wires are securely tightened, allow a little slack in the wiring and twist the gland nut clockwise until it firmly grips the cable.

The other end of this cable is then connected to your collector. This will depend on your choice of the various options of appropriate plug and socket or direct wire into the collector motor's electrical junction box. Follow the manufacturer's instructions regarding this connection.

Here's a picture showing single phase wiring connections.

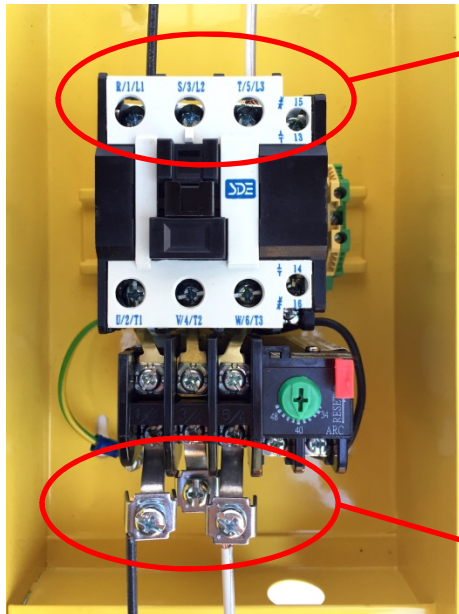

L1 and L3 connections to the input AC power.

NOTE: The 3' power cable that is wired to the System Controller is not shown for clarity. The **GROUND** connections will be added later.

Use this picture as a guide for also completing the LINE POWER wiring to L1 and L3.

T1 and T3 connections to collector motor.

AC POWER-TO-CONTACTOR WIRING

MAKE SURE THAT THE POWER CABLE IS COMPLETELY DISCONNECTED/UNPLUGGED FROM THE POWER SOURCE!

FAILURE TO DO SO COULD RESULT IN INJURY OR DEATH

Now repeat the same process for the power cable supplying AC voltage that you did for the contactor wiring using the L1 and L3 terminals. Use the above picture as a guide. The safety ground wiring will be covered shortly.

THREE PHASE AC WIRING- MOTOR CONTACTOR-TO-COLLECTOR

Here is a picture showing three phase wiring connections.

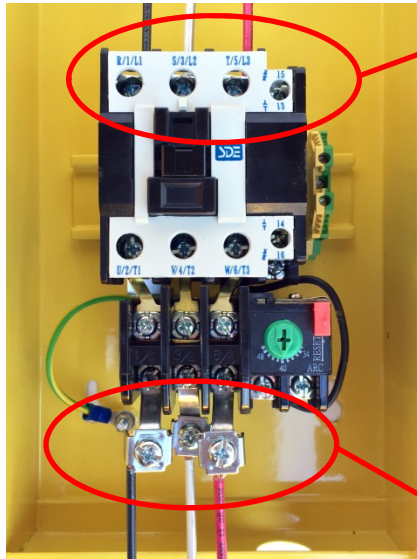

L1, L2 and L3 connections to the input 3 phase AC power.

NOTE: The 3' power cable that is wired to the System Controller is not shown for clarity. The **GROUND** connections will be added later.

Use this picture as a guide for also completing the LINE POWER wiring to L1 and L3.

T1, T2 and T3 connections to the collector motor.

Match the wire color on the L(x) and T(x) connections. Example: If the white wire going to the collector motor is connected to T1 then the white wire coming from the AC power source should be connected to L1. This ensures that the motor is correctly connected for proper operation. This is particularly important on three phase motors as they can run in the wrong rotation if incorrectly wired.

SAFETY GROUND WIRING

Now you need to connect the safety wires. At this point you should have two dangling green wires- one each from the AC power cable and the collector motor. If you are using stranded wire, twist the strands so they won't fray.

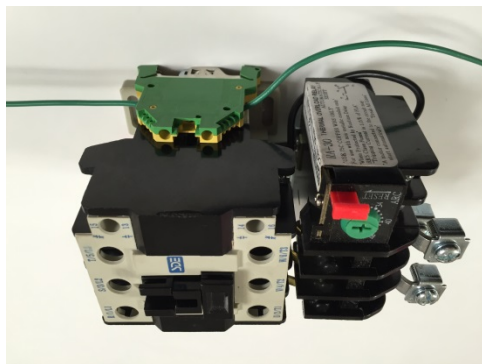

Insert each wire into one of the terminals on the terminal block and tighten the screw.

NOTE: Contactor is shown out of the enclosure for clarity.

If any of the safety wires are bare (without insulation) take particular care to make sure they are not near any of the terminals on the contactor.

The safety wires are at earth ground and should they accidentally touch any of the 'hot' terminals, sparks would fly and you would have a tripped circuit breaker!

The final wiring task is to connect the power cable to your AC source.

THE POWER MUST BE OFF BEFORE YOU START THIS CONNECTION

FAILURE TO DO SO COULD RESULT IN INJURY OR DEATH

There are several ways to connect to the power wiring to the AC voltage source. You may wire directly into a junction box, a breaker box or use a plug. There are too many variables involved in this to provide instructions other than:

AS WE STATED EARLIER, WE STRONGLY RECOMMEND THAT YOU CONSULT THE SERVICES OF A LICENSED ELECTRICIAN AND FOLLOW ALL LOCAL BUILDING CODE REQUIREMENTS.

MOTOR CONTACTOR WIRING DIAGRAMS

Here are two wiring diagrams for both single and three phase wiring:

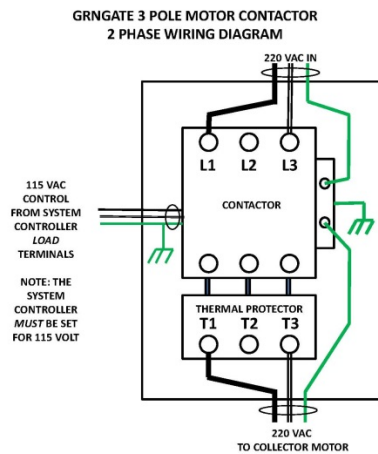

NOTE: ALTHOUGH THE POWER WIRING IS LABELED 220 VAC, THE VOLTAGE CAN BE WHATEVER IS REQUIRED FOR THE MOTOR

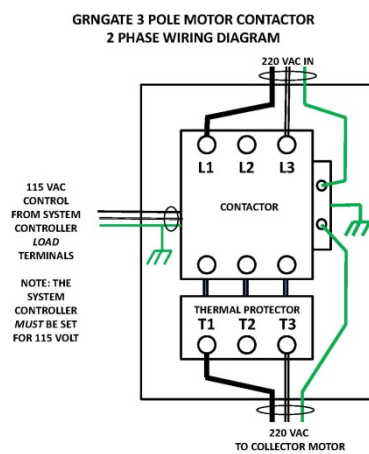

NOTE: ALTHOUGH THE POWER WIRING IS LABELED 220 VAC, THE VOLTAGE CAN BE WHATEVER IS REQUIRED FOR THE MOTOR

Congratulations!

You have completed all the wiring for the Motor Contactor.

SYSTEM SETUP

Once the wiring is done and power is turned on, you should be able to press the MANUAL button on the System Controller and have the collector turn on. If you have installed all the gates and sensors your system should now be completely automatic.

There is one option you may want to consider. With larger collector motors if they are quickly turned back on before the motor stops rotating it is possible to trip the circuit breaker in your panel. If you find you have this problem, there is a lockout delay option you can enable. This will prevent the collector from being re-energized for about 7 seconds after it has been turned off. We have found this is usually sufficient time to prevent this issue.

A small computer jumper, or shunt, is included with the Contactor kit.

Make sure that power is disconnected from the System Controller.

Remove the cover from the System Controller by removing the six cover screws.



Place the jumper on the connector header as shown in the picture.

The lockout delay is now enabled.

Please contact Grngate at any time if you have questions or concerns regarding your system. You may use our contact page at:

www.grngate.com

email us at:

info@grngate.com

or phone us between 9AM and 5PM during Pacific Time at:

408-872-0504

Again, thanks for selecting our system and we wish you many rewarding and enjoyable woodworking experiences!

NOTES: